



Required Tools:

- 1.5 Hex Driver
- 2.0 Hex Driver
- 2.5 Hex Driver
- 7.0 Hex Driver
- Thread-locker 
- Lithium Grease 

Finish Before:

- Rear Skid Plate

STEP 1

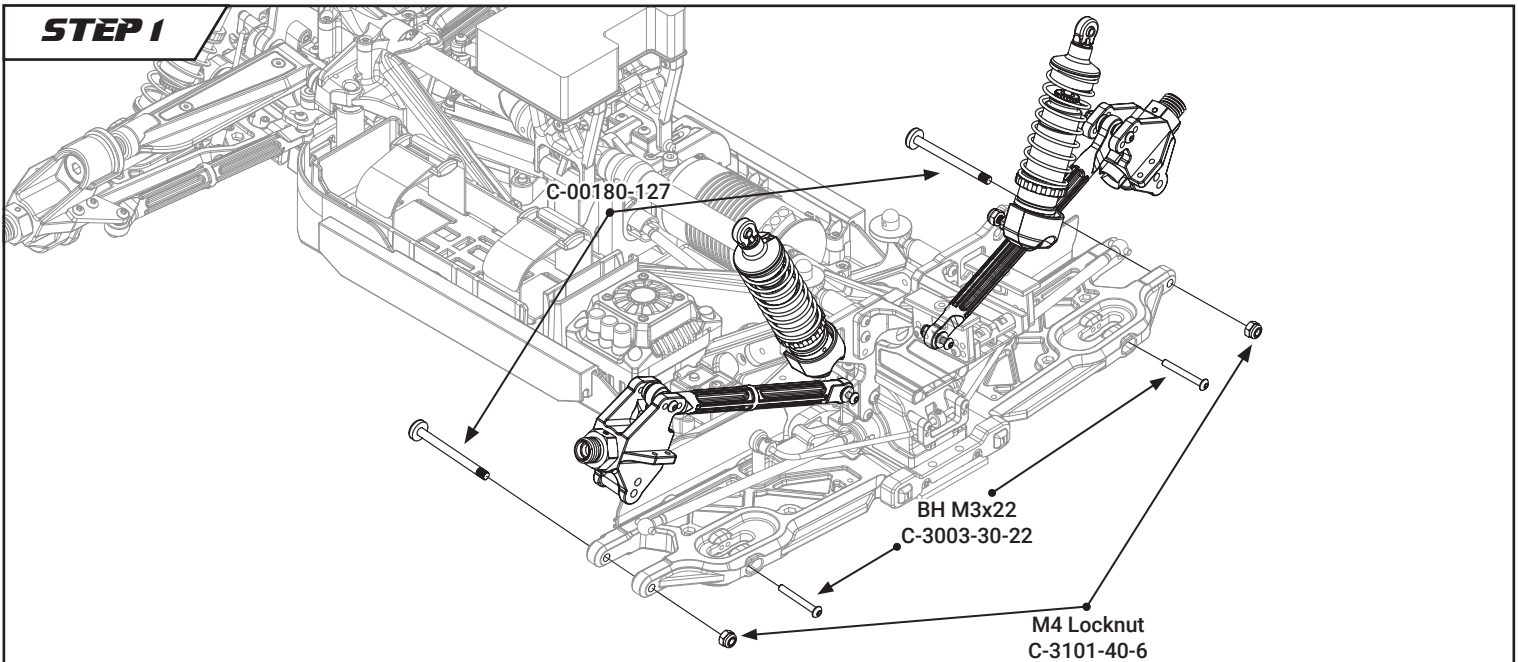

STEP 2

